



SAVE THESE INSTRUCTIONS!
MANUAL MUST BE READ BEFORE OPERATING!



MODEL: PB340
PART: 71340

WOOD PELLET GRILL & SMOKER

INSTRUCTIONS AND RECIPES

WARNING: Please read the entire manual before installation and use of this electric, pellet fuel burning appliance. Failure to follow these instructions could result in property damage, bodily injury or even death. Contact local building or fire officials about restrictions and installation inspection requirements in your area.

THE ULTIMATE 8-IN-1 GRILL

Proposition 65 Warning:
Combustion bi-products produced when using this product contain chemicals known to the State of California to cause cancer, birth defects, and other reproductive harm. This product contains chemicals known to the State of California to cause cancer, birth defects or other reproductive harm. Wash hands after handling this product.



VISIT US AT PITBOSS-GRILLS.COM FOR
FREE RECIPES,
GRILLING FAQs, TECHNIQUES & TIPS!

SAFETY INFORMATION

MAJOR CAUSES OF APPLIANCE FIRES ARE A RESULT OF POOR MAINTENANCE AND A FAILURE TO MAINTAIN REQUIRED CLEARANCE TO COMBUSTIBLE MATERIALS. IT IS OF UTMOST IMPORTANT THAT THIS PRODUCT BE USED ONLY IN ACCORDANCE TO THE FOLLOWING INSTRUCTIONS.

Please read and understand this entire manual before attempting to assemble, operate or install the product. This will ensure you receive the most enjoyable and trouble-free operation of your new wood pellet grill. We also advise you retain this manual for future reference.

DANGERS AND WARNINGS

You must contact your local home association, building or fire officials, or authority having jurisdiction, to obtain the necessary permits, mission or information on any installation restrictions, such as any grill being installed on a combustible surface, inspection requirements or even ability to use, in your area.

1. A minimum clearance of 305mm (12 inches) from combustible constructions to the sides of the grill, and 305mm (12 inches) from the back of the grill to combustible constructions must be maintained. This wood pellet appliance must not be placed under overhead combustible ceiling or overhang. Keep your grill in an area clear and free from combustible materials, gasoline and other flammable vapors and liquids.

Should a grease fire occur, turn the grill OFF and leave the lid closed until the fire is out. Do not unplug the power cord. Do not throw water on. Do not try to smother the fire. Use of an all-class (class ABC) approved fire extinguisher is valuable to keep on site. If an uncontrolled fire does occur, call the Fire Department.

2. Keep electrical supply cords and the fuel supply hose away from heated surfaces. Do not use your grill in the rain or around any water source.
3. After a period of storage, or non-use, check the burn grate for obstructions and the hopper for air blockage. Clean before use. If the grill is stored outside during the rainy season or seasons of high humidity, care should be taken to insure that water does not get into the hopper. You must always disconnect the power, before performing any service or maintenance.

Do not transport your grill while in use or while the grill is hot. Ensure the fire is completely out and that the grill is completely cool to the touch before moving.

4. It is recommended to use heat-resistant barbecue mitts or gloves when operating the grill. Do not use accessories not specified for use with this appliance. Do not put a barbecue cover or anything flammable in the storage space area under the barbecue.
5. To prevent injury or damage to the auger, the appliance features a metal hopper safety screen. This screen must not be removed unless directed by Customer Service or an authorized dealer.

This appliance is not recommended for children, persons with reduced physical, sensory or mental capabilities, or lack of experience and knowledge, unless they are under direct supervision or instruction by a person responsible for their safety.

6. Parts of the barbecue may be very hot, and serious injury may occur. Keep young children and pets away while in use.
7. Do not enlarge burn grate orifices, igniter holes or burn pots. Failure to follow this warning could lead to a fire hazard and bodily harm and will void your warranty.

DISPOSAL OF ASHES

Ashes should be placed in a metal container with a tight-fitting lid. The closed container of ashes should be placed on a non-combustible floor or on the ground, well away from all combustible materials, pending final disposal. When ashes are disposed by burial in soil, or otherwise locally dispersed, they should be retained in a closed container until all cinders have thoroughly cooled.

WOOD PELLET FUEL

This pellet cooking appliance is designed and approved for pelletized, all natural, wood fuel only. Any other type of fuel burned in this appliance will void the warranty and safety listing. You must only use all natural wood pellets, designed for burning in pellet barbecue grills. Do not use fuel with additives.

Do not use spirit, petrol, gasoline, lighter-fluid or kerosene for lighting or refreshing a fire in your grill.

At this time of printing, there is no industry standard for barbecue wood pellets, although most pellet mills use the same standards to make wood pellets for domestic use. Further information, can be found at www.pelletheat.org or the **Pellet Fuel Institute**.

Contact your local dealer on the quality of pellets in your area, and for information on brand quality. As there is no control over the quality of pellets used, we assume no responsibility to damage caused by poor quality of fuel.

CREOSOTE

Creosote, or soot, is a tar-like substance. When burning, it produces black smoke with a residue which is also black in color. Soot or creosote is formed when the appliance is operated incorrectly, such as: incorrect position of the burn grate, blockage of the combustion fan, failure to clean and maintain the burn area, or poor air-to-fuel combustion.

It is dangerous to operate this appliance should the flame become dark, sooty, or if the burn pot is overfilled with pellets. When ignited, this creosote makes an extremely hot and uncontrolled fire, similar to a grease fire. Should this happen, turn the unit OFF, let it cool completely, then inspect for maintenance and cleaning. It commonly accumulates along exhaust areas.

If creosote has formed within the unit; allow the unit to warm up at a low temperature, turn OFF the appliance, then wipe away any formation with a hand towel. Similar to tar, it is much easier to clean when warm, as it becomes liquid.

CARBON MONOXIDE

Carbon monoxide is a colorless, odorless, tasteless gas produced by burning gas, wood, propane, charcoal or other fuel. Carbon monoxide reduces the blood's ability to carry oxygen. Low blood oxygen levels can result in headaches, dizziness, weakness, nausea, vomiting, sleepiness, confusion, loss of consciousness or death.

See a doctor if you or others develop cold or flu-like symptoms while cooking or in the vicinity of the appliance. Carbon monoxide poisoning, which can easily be mistaken for a cold or flu, is often detected too late.

Alcohol consumption and drug use increase the effects of carbon monoxide poisoning.

Carbon monoxide is especially toxic to mother and child during pregnancy, infants, the elderly, smokers, and people with blood or circulatory system problems, such as anemia, or heart disease.

SAFETY LISTING

In accordance with the procedures and specifications listed in the UL Subject 2728-2009 "pellet fuel cooking appliances" and ULC/ORD C272 and Canadian CSA C22.2 #3 "for electrical features of fuel burning equipment." Pit Boss Grills pellet cooking appliances have been independently tested and listed by Intertek (an accredited testing laboratory) to ETL, UL, ULC and CSA standards.

This product has been assessed and meets EU (European Economic Area) safety, health and environmental protection requirements. Please read the safety label found inside the lid of the hopper.

This product has been assessed and meets requirements imposed or covered by regulations in Australia and New Zealand and is represented by RCM mark and number.





COPYRIGHT NOTICE

Copyright 2017. All right reserved. No part of this manual may be copied, transmitted, transcribed, stored in a retrieval system, in any form or by any means without expressed written permission of,

Dansons Inc.

3411 North 5th Avenue, Suite 500, Phoenix, AZ, USA 85013

sales@pitboss-grills.com | service@pitboss-grills.com

www.pitboss-grills.com

Toll-Free: 1-877-303-3134, Fax: 1-877-303-3135

TABLE OF CONTENTS

Safety Information	3	Care & Maintenance	17
Parts & Specs.....	7	Using Wood Pellet Fuel.....	18
Assembly Preparation.....	8	Cooking Guidelines.....	18
Assembly Instructions		Tips & Techniques	20
Mounting Legs To Main Barrel.....	8	Troubleshooting	21
Mounting The Wheels To The Legs	8	Electrical Wire Diagram	23
Installing The Bottom Shelf	9	Replacement Parts	
Securing The Lid Stopper	9	Grill Replacement Parts	24
Installing The Hopper To The Barrel	9	Hopper Replacement Parts.....	25
Assembling The Lid Handle.....	9	Warranty	
Placing The Grease Bucket.....	10	Conditions.....	25
Installing The Cooking Components	10	Exceptions.....	26
Connecting To A Power Source.....	10	Ordering Replacement Parts	26
Operating Instructions		Contact Customer Service	26
Grill Environment	11	Warranty Service	26
Grill Temperature Ranges.....	12	Accessories Sold Separately.....	27
Understanding The Control Board	13	Recipes	28
Understanding The "P" Setting	14		
Hopper Priming Procedure	15		
First Use – Grill Burn-Off.....	15		
Preheating	15		
Automatic Start-Up Procedure.....	15		
Manual Start-Up Procedure.....	16		
Shutting Off Your Smoker	16		

PARTS & SPECS

Part#	Description
1	Porcelain-Coated Cast-Iron Cooking Grids (x2)
2	Lid Stopper
3	Flame Diffuser
4	Hopper Assembly
5	Main Barrel
6	Bezel (x2)
7	Lid Handle
8	Metal Wheels (x2)
9	Stationary Leg (x2)
10	Leg with Wheel Axle (x2)
11	Grease Bucket
12	Bottom Shelf
A	Screw (x27)
B	Washer (x2)
C	Nut (x2)
D	Washer (x27)
E	Locking Washer (x27)

NOTE: Due to ongoing product development, parts are subject to change without notice. Contact Customer Service if parts are missing when assembling the unit.

PB – ELECTRIC REQUIREMENTS

110-120V, 3.3AMP, 60HZ, 275W, 3-PRONG GROUNDED PLUG

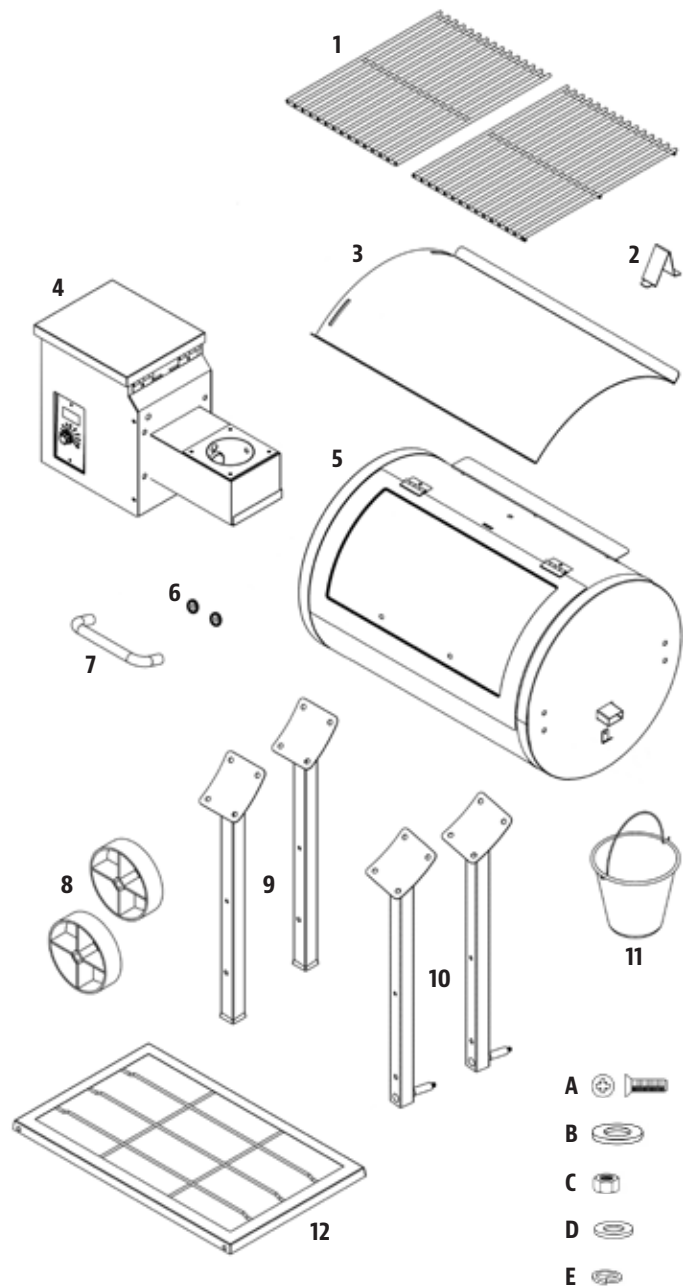

MODEL	UNIT ASSEMBLED (WxHxD)	UNIT WEIGHT	COOKING AREA	TEMP. RANGE	DIGITAL FEATURES
PB PB340	940mm x 990mm x 551mm / 37" x 39" x 21 2/3"	35.8 kg / 78.9 lb	Main - 2,200 cm ² / 341 sq. in. TOTAL - 2,200 cm² / 341 sq. in.	82-260°C / 180-500°F	Eight temperature presets, start-up and cool-down cycles, electric igniter

ASSEMBLY PREPARATION

Inspect the grill after removing the protective shipping carton, and report any damage to your dealer immediately. Shipping damage is not covered under warranty. Before assembly of product, review parts list. If any part is missing or damaged, do not attempt to assemble the product. Contact your dealer or customer service for parts.

Tools required for assembly: screwdriver, wrench and level. *Tools not included.*

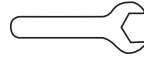
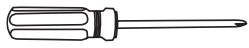

ASSEMBLY INSTRUCTIONS

NOTE: For all of the following steps, do not tighten any screws completely until all screws for that step have been installed. Once all screws have been installed, then tighten them securely.

1. MOUNTING THE LEGS TO MAIN BARREL

Parts Required:

- 1 x Main Barrel (#5)
- 2 x Stationary Leg (#9)
- 2 x Leg with Wheel Axle (#10)
- 16 x Screw (#A)
- 16 x Locking Washer (#E)
- 16 x Washer (#D)

Installation:

- Place a piece of cardboard on the floor to prevent scratching the unit. Lay the main barrel on its side, hopper end pointed upward, on the cardboard. Note illustration.
- Mount one leg with wheel to the floor end of the main barrel using four screws, locking washers, and washers, through the four pre-drilled holes. Repeat installation for second leg with wheel.

NOTE: The two pre-drilled holes on both of the support legs with wheel axles remain unused.

- Mount one stationary leg to the hopper end of the main barrel using four screws, locking washers, and washers, through the four pre-drilled holes. Repeat installation for second stationary leg.



2. MOUNTING THE WHEELS TO THE LEGS

Parts Required:

- 2 x Metal Wheel (#8)
- 2 x Washer (#B)
- 2 x Nut (#C)

Installation:

- Slide a metal wheel onto each leg with wheel axle. Secure using a washer and a nut. Spin each wheel to ensure the wheels turn freely.

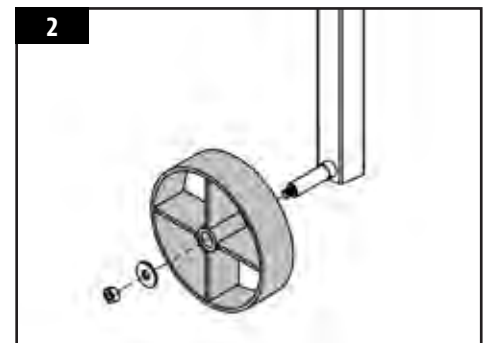

3. INSTALLING THE BOTTOM SHELF

Parts Required:

- 1 x Bottom Shelf (#12)
- 4 x Screw (#A)
- 4 x Locking Washer (#E)
- 4 x Washer (#D)

Installation:

- From underneath, secure the bottom shelf to all each leg using a screw, locking washer, and washer. Ensure the flat surface of the shelf is facing up.
- Once the shelf is secure, carefully lift the grill into an upright position.

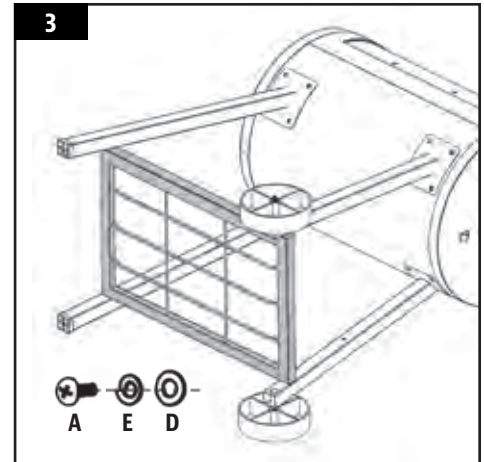

4. SECURING THE LID STOPPER

Parts Required:

- 1 x Lid Stopper (#2)
- 1 x Screw (#A)

Installation:

- Secure the lid stopper onto the top of the main barrel using one screw.

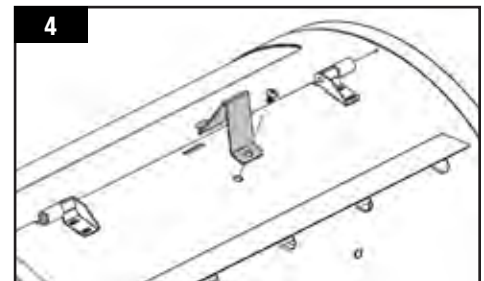

5. INSTALLING THE HOPPER TO THE BARREL

Parts Required:

- 1 x Hopper Assembly (#4)
- 4 x Screw (#A)

Installation:

- Align the burn pot end of the hopper assembly into the opening on the end of the main barrel. Insert only half-way. Connect the silver grill probe temperature wires – extruding from the main barrel – to the wire connections from the hopper assembly. Tuck the excess wire into the hopper assembly, then slide the hopper assembly completely into the opening on the end of the main barrel.
- Secure the hopper assembly to the main barrel, from the inside of the barrel, using four screws. Take care not to over-tighten to avoid stripping the screws.
- Connect the grill probe from the main barrel to the extension plug leading from the hopper assembly.

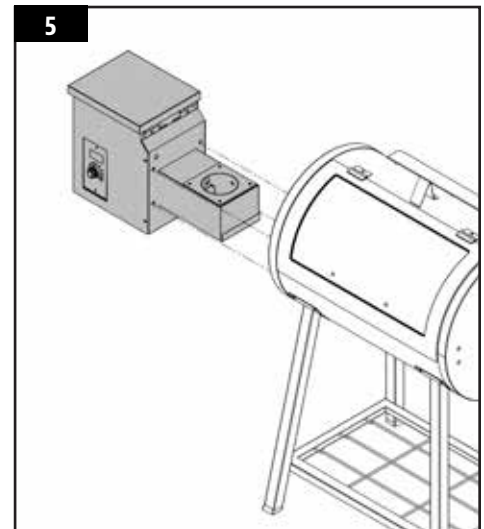

6. ASSEMBLING THE LID HANDLE

Parts Required:

- 1 x Lid Handle (#7)
- 2 x Bezel (#6)

Installation:

- From inside the barrel lid, insert one screw to protrude to the outside. Add a bezel on the screw, then hand-tighten the screw (from the inside) into the lid handle.
- Repeat same installation for other end of lid handle.

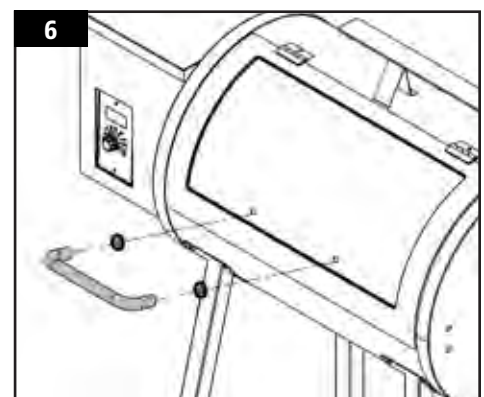

7. PLACING THE GREASE BUCKET

Parts Required:

- 1 x Grease Bucket (#11)

Installation:

- Place the grease bucket on the spout hook on the end of the main barrel. Ensure it is level to avoid grease spills.

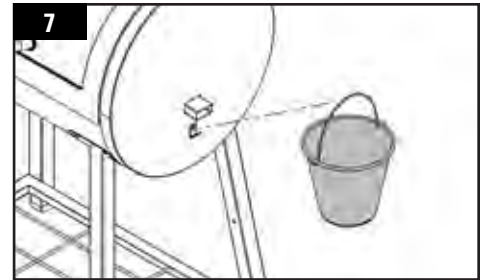

8. INSTALLING THE COOKING COMPONENTS

Parts Required:

- 2 x Cooking Grids (#1)
- 1 x Flame Diffuser (#5)

Installation:

- Insert the flame diffuser into the main grill. Rest the flame diffuser on the built-in ledge (on the inside right) of the main grill that directs grease towards the grease bucket. Slide the entire piece to the left side, and the two slots on the flame broiler main plate will fit into the rounded ledge above the burn pot. It will sit slightly at a downward angle.

NOTE: If the flame diffuser is on the base of the barrel, it is installed incorrectly.

- Place the cooking grids, side-by-side, on the grid ledge inside the main grill barrel.
- The unit is now completely assembled.

NOTE: To maintain the searing and grilling performance of your cooking grids, regular care and maintenance is required.

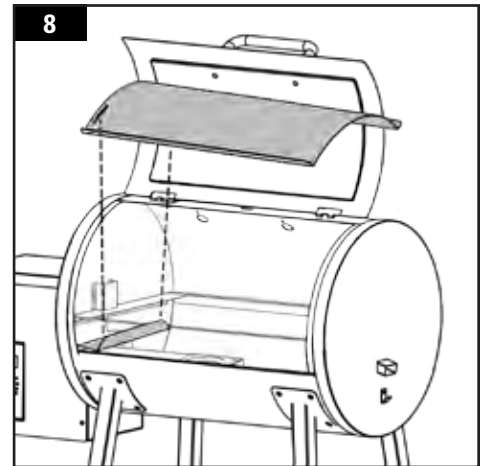

9. CONNECTING TO A POWER SOURCE

NOTE: Before plugging your Pit Boss into any electrical outlet, ensure the temperature dial is in the OFF position.

- STANDARD OUTLET**
This appliance requires 110 volt, 60hz, 275w, 5 amp service. It must be a 3-prong grounded plug. Ensure grounded end is not broken off before use. The control uses a 5 amp, 120 volt, fast-blow fuse to protect the board from the igniter.
- GFCI OUTLETS**
This appliance will work on most GFCI outlets, with a recommended size of 15 amp service. If your GFCI outlet is highly sensitive to power surges, it will likely trip during the start-up phase of operation. During the start-up phase, the igniter draws 200-700 watts of electricity which can be too much power for a GFCI outlet to handle. The quality of the GFCI does not matter, but rather the sensitivity; each time it trips, it increases in sensitivity. If the GFCI keeps tripping, replace the outlet or change to a non-GFCI outlet.
- ON THE ROAD**
Disconnect the igniter from the main wiring harness. Use the manual start-up procedure. A Pit Boss unit can operate using a 12 volt, 100 watt inverter plugged into your automobile outlet. To use the automatic igniter, it is recommended to use a minimum of a 1000 watt inverter.

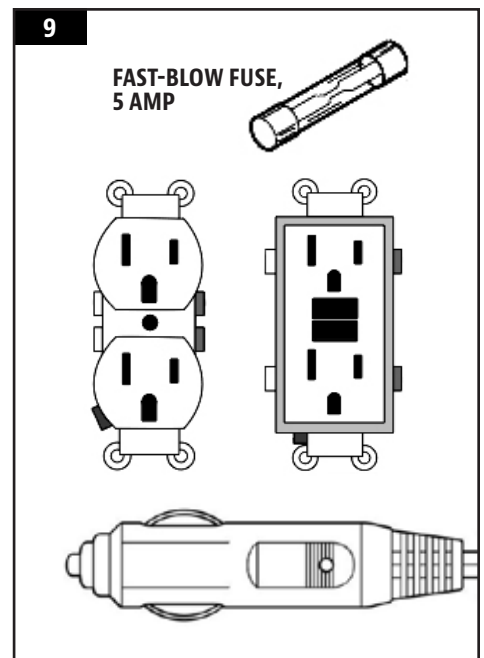

OPERATING INSTRUCTIONS

With today's lifestyle of striving to eat healthy and nutritious foods, one factor to consider is the importance of reducing fat intake. One of the best ways to cut down on fat in your diet is to use a low fat method of cooking, such as grilling. As a pellet grill uses natural wood pellets, the savory wood flavor is cooked into the meats, reducing the need for high sugar content sauces. Throughout this manual, you will notice the emphasis on grilling food slowly at LOW or MEDIUM (135-190°C / 275-375°F) temperature settings.

GRILL ENVIRONMENT

1. WHERE TO SET-UP THE GRILL

With all outdoor appliances, outside weather conditions play a big part in the performance of your grill and the cooking time needed to perfect your meals. The Pit Boss, because of its single wall construction, should be considered as a 2 to 3 season grill, depending on where you live.

All Pit Boss units should keep a minimum clearance of 305mm (12 inches) from combustible constructions, and this clearance must be maintained while the grill is operational. This appliance must not be placed under overhead combustible ceiling or overhang. Keep your grill in an area clear from combustible materials, gasoline and other flammable vapors and liquids.

2. COLD WEATHER COOKING

As it becomes cooler outside, that does not mean that grilling season is over! The crisp cool air and heavenly aroma of smoked foods will help cure your winter blues.

Follow these suggestions on how to enjoy your grill throughout the cooler months:

- If smoking at low temperatures fails, increase the temperature slightly to achieve the same results.
- Organize – Get everything you require ready in the kitchen before you head outdoors. During the winter, move your grill to an area that is out of the wind and direct cold. Check local bylaws regarding the proximity of your grill in relation to your home and/or other structures. Put everything you need on a tray, bundle up tight, and get it done!
- To help keep track of the outside temperature, place an outdoor thermometer close to your cooking area. Keep a log or history of what you cooked, the outdoor temperature, and the cooking time. This will help later down the road to help you determine what to cook and how long it will take.
- In very cold weather, increase your preheating time by at least 20 minutes.
- Avoid lifting the lid any more than necessary. Cold gusts of wind can completely cool your grill temperature. Be flexible with your serving time; add about 10 – 15 minutes extra cooking time each time you open the lid.
- Have a heated platter or a dish cover ready to keep your food warm while making the trip back inside.
- Ideal foods for winter cooking are those that require little attention, such as roasts, whole chickens, ribs, and turkey. Make your meal preparation even easier by adding simple items such as vegetables and potatoes.

3. HOT WEATHER COOKING

As it becomes warmer outdoors, the cooking time will decrease. Proper dress is important when it gets really hot: shorts, shirt, shoes, hat, apron and a generous slab of suntan lotion is recommended.

Follow these few suggestions on how to enjoy your grill throughout the hot months:

- Adjust your cooking temperatures downward. This helps to avoid unwanted flare-ups.
- Use a meat thermometer to determine the internal temperature of your foods. This helps in preventing your meat from over cooking and drying out.
- Even in hot weather it is still better to cook with the lid of your grill down.
- You can keep foods hot by wrapping them in foil, and placing them in an insulated cooler. Stuff crumpled up newspaper around the foil and this will keep food hot for 3 to 4 hours.

GRILL TEMPERATURE RANGES

Temperature readouts on the control board may not exactly match the thermometer. All temperatures listed below are approximate and are affected by the following factors: outside ambient temperature, the amount and direction of wind, the quality of pellet fuel being used, the lid being opened, and the quantity of food being cooked.

- **HIGH TEMPERATURE (204-260°C / 400-500°F)**

This range is best used to sear and grill at a high heat. Use in tandem with the flame broiler for indirect or direct flame cooking to create those "dirty or blue" steaks, as well as flame-kissed vegetables, garlic toast or even s'mores!

High temperature is also used to preheat your grill, and be used as the burn-off temperature to clean off the cooking grids and flame broiler after use. Additionally, high heat is used in extreme cold weather conditions or if cooking with the hood open.

- **MEDIUM TEMPERATURE (135-177°C / 275-350°F)**

This range is best for baking, roasting, and finishing off that slow smoked creation. Cooking at these temperatures will greatly reduce the chances of a grease flare-up. Ensure that the flame broiler slider is in the closed position, covering the slotted openings. Great range for cooking anything wrapped in bacon, or where you want versatility with control.

- **LOW TEMPERATURE (82-122°C / 180-250°F)**

This range is used to slow roast, increase smoky flavor, and to keep foods warm. Infuse more smoke flavor and keep your meats juicy by cooking longer at a lower temperature (also known as **low and slow**). Highly recommended for the big turkey at Thanksgiving, juicy ham at Easter, or the huge holiday feast.

Smoking is a variation on true barbecuing and is truly the main advantage of grilling on a wood pellet grill. There are two types of smoking: hot smoking and cold smoking.

- **Hot smoking**, another name for **low and slow** cooking, is generally done at 82-122°C / 180-250°F. Hot smoking works best when longer cooking time is required, such as large cuts of meats, fish, or poultry.
- **Cold smoking** is when the food is located so far away from the fire that it smokes without cooking, and at temperatures of 15-32°C / 60-90°F.

TIP: To intensify that savory flavor, switch to SMOKE (low) temperature range immediately after putting your food on the grill. This allows the smoke to penetrate the meats, before the pores of the meat close at 49°C / 120°F.

The key is to experiment with the length of time you allow for smoking, before the meal is finished cooking. Some outdoor chefs prefer to smoke at the end of a cook, allowing the food to keep warm until ready to serve. Practice makes perfect!

UNDERSTANDING THE CONTROL BOARD

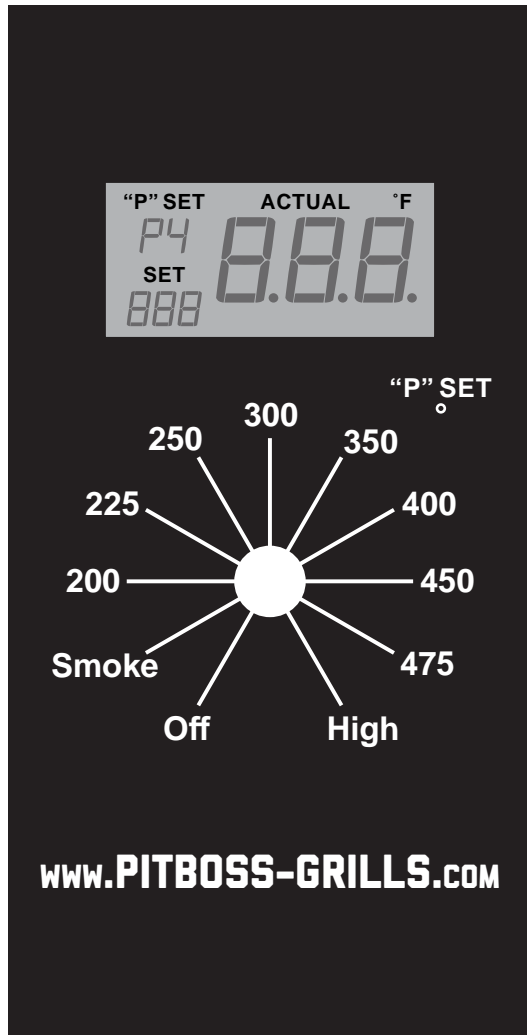

FEATURE	DESCRIPTION
LCD Screen	Displays grill temperature, smoke setting ("P" SET), igniter, temperature status, and error.
Temperature Dial	Select one of the following: SMOKE, HIGH, or one of the eight temperature presets.
"P" SET (P0-P7)	Select one of the seven temperature fine tunings. Allows for larger temperature control to accommodate to your cooking style and cooking environment. Best used when the temperature dial is in SMOKE mode. The default setting is P4.
SMOKE (Start-up/LOW)	Start-up the grill at this temperature. The grill operates in a timed mode at the lowest temperature. This level can be adjusted using the "P" SET button. This setting works in conjunction with the temperature dial presets.
HIGH	Grill operates at the highest heat level. When the lid is open, the grill will run at this speed.

LCD READOUT	DESCRIPTION
888	Displays momentarily when the grill is connected to AC power.
ACTUAL Temperature	Grill temperature is displayed in 5 degree (°F) increments.
Flashing ACTUAL Temperature	When grill temperature is below 66°C / 150°F.
Flashing Dots	Indicates the igniter is ON.
"P" SET	Indicates the current "P" setting selected.
"ErH" Error Message	The grill has overheated, possibly due to grease fire or excess fuel.
"ErR" Error Message	Temperature probe wire not making connection.
"ErP" Error Message	Temperature dial was not OFF when last connected to AC Power, or power outage occurred while in operation.

UNDERSTANDING THE "P" SETTING

The main benefit to the "P" SET (setting) button is that it allows the cook to have fine tuned control of their grill to compensate for ambient temperature, humidity, wind, environmental changes, pellet fuel type and quality.

When the recessed "P" SET button is pushed, the "P" setting displayed on the LCD screen will flash and change to the next value (upward). Once P7 is reached, it will restart at P0. There are eight "P" settings, ranging from P0 to P7. The recessed "P" SET button can be pushed using a thin-tipped object, such as a pen tip, toothpick, kabob skewer, or screwdriver.

IMPORTANT: Do not push the "P" SET button too hard, as this may cause damage. Only a light push is needed.

"P" SET	AUGER CYCLE (seconds)	
	ON	OFF
P0	18	55
P1	18	70
P2	18	85
P3	18	100
*P4	18	115
P5	18	130
P6	18	140
P7	18	150

** default setting*

1. USING THE "P" SETTING IN SMOKE MODE

Anytime the temperature dial is set to SMOKE, such as the **start-up cycle**, the auger will run on more of a manual mode of cooking versus using one of the preset dial temperatures.

First, the auger will continuously turn and feed pellets for four minutes. After four minutes, the auger begins to run a feed cycle based on the "P" setting selected on the Digital Control Board. The default setting is P4.

- **MORE SMOKE FLAVOR, LESS HEAT** (↑ "P" SETTING / ↓ FUEL FEED)
When hot smoking – increasing the infusion of more natural wood flavor – increase the "P" setting to allow for longer cycles between auger feeds. This results in keeping a lower temperature output, which increases cook time (also known as **low and slow**). This results in a deeper **smoke ring** and more smoke flavor. Care must be taken when using the higher "P" settings, such as P6 or P7, as this could result in the fire going out in the burn pot.
- **LESS SMOKE FLAVOR, MORE HEAT** (↓ "P" SETTING / ↑ FUEL FEED)
A lower "P" setting will result in a higher grill temperature output and higher pellet consumption due to more frequent cycles.

IMPORTANT: When selecting a SMOKE setting after a temperature dial preset (such as preheating at high heat), the auger will continuously turn and feed pellets for four minutes. This will momentarily raise the temperature, but temperature will decrease and stabilize once the "P" setting cycle begins (approximately five to ten minutes).

2. USING THE "P" SETTING WITH A TEMPERATURE DIAL PRESET

Anytime the temperature dial is set to one of the temperature dial presets (95-245°C / 200-475°F), the auger will run on a controlled setting of pellet feeding to maintain the preset temperature selected.

Once the grill has preheated on SMOKE, select the desired temperature using the temperature dial presets. The auger will begin to run continuously until the desired preset temperature is reached. Once reached, the auger will run a feed cycle based on the "P" setting selected on the Digital Control Board, aiming to hold at the preset temperature selected.

NOTE: When using a temperature dial preset, lowering the "P" setting, such as P1, will decrease large fluctuations in temperature. Similar to a campfire, fueling the burn pot (fire) more frequently will result in less heat fluctuation.

HOPPER PRIMING PROCEDURE

These instructions should be followed the first time the grill is ignited, and each time the grill runs out of pellets in the hopper:

1. Remove all cooking components from the interior of the grill.
2. Open the hopper lid. Make sure there are no foreign objects in the auger or hopper.
3. With the temperature dial in the OFF position, plug the power cord into a power source.
4. Turn the temperature dial to the SMOKE position. Check the following items:
 - That the auger is turning. Do not place fingers or objects in the auger tube. This can cause injury.
 - Place your hand above the fire pot and feel for air movement. Do not place your hand or fingers inside the fire pot. This can cause injury.
 - After approximately a minute, you should smell the igniter burn off and begin to feel the air getting warmer. The igniter tip does not glow red hot. Do not touch the igniter. This item gets extremely hot and will burn.
5. Turn the temperature dial to OFF.
6. Fill the hopper with all natural barbecue wood pellets.
7. Turn the temperature dial to SMOKE. Allow the pellets to ignite and create flame. Once flames are coming out of the fire pot, turn the temperature dial to OFF, and let the grill cool down.
8. After grill has cooled, re-install the cooking components into grill. The grill is now ready to use.

FIRST USE – GRILL BURN-OFF

Once your hopper has been primed and before cooking on your grill for the first time, it is important to complete a grill burn-off. Start the grill and operate at high heat (over 233°C / 450°F) with the lid down for 30 to 40 minutes to burn-off the grill and rid it of any foreign matter.

PREHEATING

It is important to allow your grill to preheat before every cook session. This allows the grill and cooking grids to heat up quicker, kill off bacteria and other pathogens leftover from past grill sessions, and the grill is then able to maintain its cooking temperature once your food is placed in the cooking area. **Preheat with the lid closed.**

IMPORTANT: The outside ambient temperature, weather conditions, and quality of wood pellets will all affect your cooking temperature. Observe the time it takes to reach your desired temperature, and adjust your cooking time as needed.

AUTOMATIC START-UP PROCEDURE

1. Ensure the temperature dial is in the OFF position. Plug the power cord into a grounded power source.
2. Check burn pot to ensure there is no obstruction for proper ignition. Open the hopper lid. Ensure there are no foreign objects in the hopper or auger feed system. Fill hopper with dry, barbecue hardwood pellets.
3. Open the barrel lid. **The lid must remain open during the start-up cycle.**
4. Turn the temperature dial to SMOKE. This will activate the start-up cycle. The auger feed system will begin to turn, the igniter will begin to glow and the fan will supply air to the fire pot. The grill will produce smoke while the start-up cycle is taking place. The pellets will have ignited once the smoke has cleared. To confirm the start-up cycle has begun properly, listen for a torchy roar, and notice some heat being produced.
5. Preheat your grill. Close the lid. Turn the temperature dial to 177°C / 350°F, to allow the unit to preheat for approximately 15 to 20 minutes.
6. After preheating is complete, you are ready to enjoy your grill!

IMPORTANT: When selecting a SMOKE setting after a temperature dial preset (such as preheating at high heat), the auger will continuously turn and feed pellets for four minutes. This will momentarily raise the temperature, but temperature will decrease and stabilize once the "P" setting cycle begins (approximately five to ten minutes).

IGNITER FAILURE PROCEDURE

If for any reason your electric igniter fails, check the following steps, or start your grill using the manual method.

1. Turn the temperature dial to the OFF position. Open the lid. Remove the cooking components from the grill. Remove all unburnt pellets and ash from the burn pot. Avoid touching the igniter to avoid injury, as it will be extremely hot.
2. Once all parts are removed and cleaned, turn the temperature dial to SMOKE. Check the following:
 - Visually confirm that the igniter is working by placing your hand above the burn pot and feeling for heat.
 - Visually confirm that the igniter is protruding approximately 13mm / 0.5 inches in the burn pot.
 - Visually confirm that the auger is dropping pellets into the burn pot.
 - Confirm that the combustion fan is working by listening for it.
3. If any of the above points are not working, follow ***Troubleshooting*** instructions.

MANUAL START-UP PROCEDURE

1. Ensure the temperature dial is in the OFF position. Plug the power cord into a grounded power source.
2. Check burn pot to ensure there is no obstruction for proper ignition. Open the hopper lid. Ensure there are no foreign objects in the hopper or auger feed system. Fill hopper with dry, all natural hardwood barbecue pellets.
3. Open the barrel lid. Remove the cooking components to expose the burn pot. Place a generous handful of pellets into the burn pot. Squirt a gelled fire starter, or other appropriate pellet starter, over the top of the pellets. A small amount of solid fuel fire starter, such as one composed of sawdust and wax, or wood shavings, is also appropriate. Add another small amount of pellets over the burn pot.

NOTE: Do not use spirit, petrol, gasoline, lighter-fluid or kerosene for lighting or refreshing a fire in your grill.

4. Light the contents of the burn pot using a long match or long-nosed lighter. Allow the starter to burn for 3 to 5 minutes. Do not attempt to add more starter into the burn pot. This can cause injury.
5. Quickly and carefully replace the cooking components to the inside of the barrel. **The lid must remain open during the start-up cycle.**
6. Continue start-up by following steps four through six of ***Automatic Start-Up Procedure***.

SHUTTING OFF YOUR GRILL

1. When finished cooking, turn the temperature dial to 177°C / 350°F and close the lid. Let your grill run for 5 to 10 minutes to go through its normal cleaning method. If you have been preparing foods that are extra greasy, allow the grill to burn-off for an extra 10 to 20 minutes. This will reduce the chance of causing a grease fire for the next start-up.
2. Once the grill burn-off is complete, keep the lid closed and turn the temperature dial down to 93°C / 200°F for five minutes to allow any pellets to burn out.
3. After five minutes, with the lid remaining closed, turn the temperature dial to OFF. The grill will begin its automatic cool-down cycle. The auger system will stop feeding fuel, the flame will burn out, and the fan will continue to run until the cool-down cycle is complete.

CARE AND MAINTENANCE

Any Pit Boss unit will give you many years of flavorful service with minimum cleaning. An important step is allowing the grill and cooking grids to self-clean by running the grill at a high temperature for 5 to 10 minutes after each use. Follow these cleaning and maintenance tips to service your grill:

1. HOPPER ASSEMBLY

- The hopper includes a clean-out feature to allow for ease of cleaning and change out of pellet fuel flavors. To empty, locate the plate and the cover of the drop chute on the back side of the hopper. Place a clean, empty pail under the drop chute cover, then remove the cover piece. Unscrew the plate, slide outwards, and pellets will empty.

NOTE: Use a long handled brush or shop-vac to remove excess pellets, sawdust, and debris for a complete clean-out through the hopper screen.

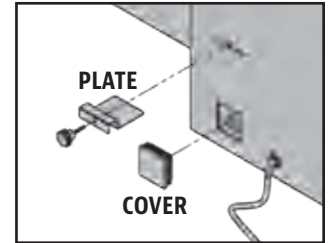

- Check and clean off any debris from the fan air intake vent, found on the bottom of the hopper. Once the hopper access panel is removed (see **Electric Wire Diagram** for diagram), carefully wipe off any grease build-up directly on the fan blades. This ensures airflow is sufficient to the feed system.

2. INSIDE SURFACES

- It is recommended to clean your burn pot after every few uses. This will ensure proper ignition and avoid any hard build-up of debris or ash in the burn pot.
- Use a long-handled grill cleaning brush (brass or soft metal), remove any food or build-up from the cooking grids. Best practice is to do this while they are still warm from a previous cook. Grease fires are caused by too much fallen debris on the cooking components of the grill. Clean the inside of your grill on a consistent basis. In the event you experience a grease fire, keep the grill lid closed to choke out the fire. If the fire does not go out quickly, carefully remove the food, turn the grill off, and shut the lid until the fire is completely out. Lightly sprinkle baking soda, if available.
- Check your grease bucket often, and clean out as necessary. Keep in mind the type of cooking you do.

IMPORTANT: Due to high heat, do not cover the flame broiler or probes with aluminum foil.

3. OUTSIDE SURFACES

- Wipe your grill down after each use. Use warm soapy water to cut the grease. Do not use oven cleaner, abrasive cleansers or abrasive cleaning pads on the outside grill surfaces. **All painted surfaces are not covered under warranty**, but rather are part of general maintenance and upkeep. For paint scratches, wearing, or flaking of the finish, all painted surfaces can be touched up using high heat BBQ paint.
- Use a grill cover to protect your grill for complete protection! A cover is your best protection against weather and outside pollutants. When not in use or for longterm storage, keep the unit under a cover in a garage or shed.

CLEANING FREQUENCY TIME TABLE (NORMAL USE)

ITEM	CLEANING FREQUENCY	CLEANING METHOD
Bottom of Main Grill	Every 5-6 Grill Sessions	Scoop Out, Shop-Vac Excess Debris
Burn Pot	Every 2-3 Grill Sessions	Scoop Out, Shop-Vac Excess Debris
Cooking Grids	After Each Grill Session	Burn Off Excess, Brass Wire Brush
Flame Broiler	Every 5-6 Grill Sessions	Scrape Main Plate with Slider, Do Not Wash Clean
Grease Bucket	After Each Grill Session	Scrub Pad & Soapy Water
Auger Feed System	When Pellet Bag is Empty	Allow Auger to Push Out Sawdust, Leaving Hopper Empty
Hopper Electric Components	Once A Year	Dust Out Interior, Wipe Fan Blades with Soapy Water
Air Intake Vent	Every 5-6 Grill Sessions	Dust, Scrub Pad & Soapy Water
Temperature Probe	Every 2-3 Grill Sessions	Scrub Pad & Soapy Water

USING WOOD PELLET FUEL

They appear no thicker than the eraser on the end of a pencil. People who see them for the first time think they look like rabbit food; however, there is nothing small about the heat or flavor in barbecue wood pellet fuel. These clean-burning barbecue wood pellets generate about 8200 BTU's per pound with very little ash, a low moisture content (5-7%), and are carbon neutral.

Barbecue wood pellets are produced by pure raw material (sawdust) being pulverized with a hammer-mill, and the material is pushed through a die with pressure. As the pellet is forced through the die, it is cut, cooled, screened, vacuumed, and then bagged for consumer use. Check with your local dealer for flavors available in your area.

FLAVOR GUIDELINES

- HICKORY BLEND** 

Rich, smoky bacon-like flavor. Considered the "Kings of the Woods"
- MESQUITE BLEND** 

Strong, tangy, spicy flavor. Think Tex-Mex cuisine.
- APPLE BLEND** 

Smoky, mild sweetness flavor. Highly recommended for baking.
- CHERRY BLEND** 

Slightly sweet, but also tart. Gives a rosy tint to light meals.
- WHISKEY BARREL BLEND** 

Strong, sweet smoke with aromatic tang. Perfect for red meats.
- COMPETITION BLEND** 

Perfect blend of sweet, savory, and tart. Used by many professional grillers.

NOTE: Always store wood pellets in a dry area. Avoid any contact or exposure to moisture will result in lower heat output or cause the pellets to swell and break apart. Use a moisture proof, resealable tub or bucket for proper storage.

COOKING GUIDELINES

Smoking and grilling styles of cooking can give you different results based on time and temperature. For best results, keep a record of what you cooked, at what temperature, how long you cooked for, and the results. Adjust to your taste for the next time. Practice makes perfect.

The culinary art of hot smoking refers to longer cooking times, but results in more natural wood flavor (and a sought-after Pink Ring) on your meats. Higher cooking temperatures result in a shorter cooking time, locking in less smoke flavor.

TIP: For best results, allow time for meats to rest after cooking. This allows the natural juices to migrate back into the meat fiber, giving a much juicier, flavorful cut. Resting times can be as little as 3 minutes and up to 60 minutes, depending on the size of the protein.

STYLE OF COOKING	HOT SMOKING	ROAST	BAKING (Medium)	GRILL/BAKE (Medium/High)	SEAR (High)
Temperature Range	93-135°C / 200-275°F	135-162°C / 275-325°F	162-190°C / 325-375°F	204-232°C / 400-450°F	232-260°C / 450-500°F

BEEF	SIZE	HEAT	APPROXIMATE COOKING TIME		
			Rare - 54°C / 130°F	Medium - 60°C / 140°F	Well Done - 65°C / 150°F
Steak <i>(New York, Porter-house, Rib-eye, Sirloin, T-bone, or Tenderloin)</i>	1.9 cm / ¾" 2.5 cm / 1" 3.8 cm / 1½" 5 cm / 2"	High	Sear 8-10 minutes Sear 10-12 minutes Sear 10 minutes, grill 8-10 minutes Sear 10 minutes, grill 10-14 minutes		
Skirt Steak	0.6 - 12.7 cm / ¼" - ½"	High	5-7 minutes		
Flank Steak	0.45 - 0.86 kg / 1 - 1½ lbs., 1.9 cm / ¾"	Medium	Sear 4 minutes, grill 8-10 minutes		
Kabob	2.5 - 3.8 cm / 1 - 1½" cubes	Medium	Grill 10 - 12 minutes		
Tenderloin, whole	1.58 - 1.81 kg / 3½ - 4 lbs.	High/Medium	Sear 10 minutes, grill 15-20 minutes		
Ground Beef Patty	1.9cm / ¾"	High/Medium	Sear 4 minutes, grill 4-6 minutes		
Rib-eye Roast, boneless	2.26 - 2.72 kg / 5 - 6 lbs.	Medium	1½ - 2 hours		
Tri-tip Roast	0.9 - 1.13 kg / 2 - 2½ lbs.	High/Medium	Sear 10 minutes, grill 20-30 minutes		
Rib Roast	5.44 - 6.35 kg / 12 - 14 lbs.	Medium	2½ - 2¾ hours		
Veal Loin Chop	2.5cm / 1"	Medium	10 - 12 minutes direct		
Brisket	7.25 - 3.62 kg / 16 -18 lbs.	Hot Smoke	Cook until internal temperature reaches 91°C / 195°F		

PORK	SIZE	Precooked to Reheat 60°C / 140°F	Medium 66°C / 150°F	Well Done 71°C / 160°F
Ham <i>(Fully Cooked & Boneless Portion, Smoked Picnic Whole & Bone-In)</i>	2.5 cm / 1" 1.36-1.81 kg / 3-4 lbs. 1.81-2.72 kg / 4-6 lbs. 2.26-3.62 kg / 5-8 lbs. 4.53-5.44 kg / 10-12 lbs.	12 minutes 50 minutes - 1 hour 1 - 2 hours 1 - 2½ hours 2 - 2¾ hours		
Loin Roast	1.36-1.81 kg / 3 - 4 lbs.		1 - 2 hours	2 - 3 hours
Rib Crown Roast	1.81-2.26 kg / 4 - 5 lbs.		1½ - 2 hours	2 - 3 hours
Chop <i>(loin, rib)</i>	1.9-2.5 cm / ¾" - 1" 3.1-3.9 cm / 1¼" - 1½"		10 - 12 minutes 14 - 18 minutes	
Tenderloin	1.9-2.5 cm / ¾" - 1"		20 - 30 minutes	30 - 45 minutes
Loin Roast, boneless	1.36-2.26 kg / 3-5 lbs.		1¼ - 1¾ hours	1¾ - 2½ hours
Boston Butt <i>(Pork Shoulder)</i>	3.62-4.53 kg / 8-10 lbs.			93 - 98°C / 200 - 210°F Internal Temperature

TIPS & TECHNIQUES

Follow these helpful tips and techniques, passed on from Pit Boss owners, our staff, and customers just like you, to become more familiar with your grill:

1. *FOOD SAFETY*

- Keep everything in the kitchen and cooking area clean. Use different platters and utensils for the cooked meat than the ones you used to prepare or transport the raw meat out to the grill. This will prevent cross contamination of bacteria. Each marinade or basting sauce should have its own utensil.
- Keep hot foods hot (above 60°C / 140°F), and keep cold foods cold (below 3°C / 37°F).
- A marinade should never be saved to use at a later time. If you are going to use it to serve with your meat, be sure to bring it to a boil before serving.
- Cooked foods should not be left out in the heat for more than an hour. Do not leave hot foods out of refrigeration for more than two hours.
- Defrost and marinate meats by refrigeration. Do not thaw meat at room temperature or on a counter top. Bacteria can grow and multiply rapidly in warm, moist foods. Wash hands thoroughly with hot, soapy water before starting any meal preparation and after handling fresh meat, fish and poultry.

2. *COOKING PREPARATION*

- When switching from a high temperature to a low temperature, lift the lid and leave it open until the actual temperature is close to your desired temperature. This speeds up the process and ensures the fire will not go out.
- Be prepared, or ***Mise en Place***. This refers to preparing the cooking recipe, fuel, accessories, utensils, and all ingredients you require at grill side before you start cooking. Also, read the entire recipe, start to finish, before lighting the grill.
- A BBQ floor mat is very useful. Due to food handling accidents and cooking spatter, a BBQ floor mat would protect a deck, patio, or stone platform from the possibility of grease stains or accidental spills.

3. *GRILLING TIPS AND TECHNIQUES*

- To infuse more smoke flavor into your meats, cook longer and at lower temperatures (also known as ***low and slow***). Meat will close its fibers after it reaches an internal temperature of 49°C / 120°F. Misting, or mopping, are great ways to keep meat from drying out.
- While searing your meats, cook with the lid down. Always use a meat thermometer to determine the internal temperature of the foods you are cooking. Smoking foods with hardwood pellets will turn meats and poultry pink. The band of pink (after cooking) is referred to as a ***smoke ring*** and is highly prized by outdoor chefs.
- Sugar-based sauces are best applied near the end of cooking to prevent burning and flare-ups.
- Leave open space between the foods and the extremities of the barrel for proper heat flow. Food on a crowded grill will require more cooking time.
- Use a set of long-handled tongs for turning meats, and a spatula for turning burgers and fish. Using a piercing utensil, such as a fork, will prick the meat and allow the juices to escape.
- Foods in deep casserole dishes will require more time to cook than a shallow baking pan.
- It's a good idea to put cooked food onto a heated platter, keeping the food warm. Red meats, such as steak and roasts, benefit from resting for several minutes before serving. It allows the juices that were driven to the surface by heat to ease back to the center of the meat, adding more flavor.

TROUBLESHOOTING

Proper cleaning, maintenance and the use of clean, dry, quality fuel will prevent common operational problems. When your Pit Boss grill is operating poorly, or on a less frequent basis, the following troubleshooting tips may be helpful.

For FAQ, please visit www.pitboss-grills.com and click SUPPORT. You may also contact your local Pit Boss authorized dealer or contact Customer Service for assistance.

WARNING: Always disconnect the electrical cord prior to opening the grill for any inspection, cleaning, maintenance or service work. Ensure the grill is completely cooled to avoid injury.

PROBLEM	CAUSE	SOLUTION
LCD Screen Will Not Light Up	Grill is not properly plugged in.	Ensure grill is plugged into a working power source. Remove hopper access panel (see <i>Electric Wire Diagram</i> for diagram), and ensure all wire connections are firmly connected.
	The fuse on the circuit board has blown out	Remove the two screws on the front facing panel of the hopper, above and below the Digital Control Board. Lift up slightly, and carefully pull it forward. Check the fuse for a broken wire or if the wire has turned black. If yes, fuse needs to be manually replaced.
	The GFCI outlet has been tripped.	Remove hopper access panel (see <i>Electric Wire Diagram</i> for diagram), and ensure all wire connections are firmly connected and dry. Ensure GFCI is a minimum 10 Amp service.
	Temperature Dial	Temperature dial is still in the OFF position. Turn temperature dial to SMOKE to start-up the unit. The LCD screen will light up.
Fire in Burn Pot Will Not Light	Auger Not Primed	Before the unit is used for the first time <u>or</u> anytime the hopper is completely emptied out, the auger must be primed to allow pellets to fill the fire pot. If not primed, the igniter will timeout before the pellets reach the fire pot. Follow <i>Hopper Priming Procedure</i> .
	Auger Motor Is Jammed	Remove cooking components from the grill barrel. Turn the temperature dial to SMOKE, and visually inspect the auger feed system. Remove the two screws on the front facing panel of the hopper, above and below the Digital Control Board. Lift up slightly, and carefully pull it forward. Inspect the auger feed motor rotation. Ensure the auger motor bracket is not damaged. If not operating properly, call Customer Service for a replacement part.
	Igniter Failure	Electric igniter needs to be replaced. Follow <i>Manual Start-up Procedure</i> to continue use of grill; however, contact Customer Service for a replacement part.
"ErH" Error Message	The grill has overheated, possibly due to grease fire or excess fuel.	Turn the temperature dial to OFF, and allow grill to cool. Follow <i>Care and Maintenance</i> instructions. After maintenance, remove pellets, and confirm positioning of all component parts. To clear the error, turn the temperature dial to OFF, open the lid, wait 3 to 4 minutes, then select desired temperature.
"ErR" Error Message	Temperature probe wire not making connection.	Remove hopper access panel (see <i>Electric Wire Diagram</i> for diagram), and check for any damage. Ensure probe wire connections are firmly connected, and connected correctly to the digital control board.
"ErP" Error Message	Temperature dial was not OFF when last connected to AC Power.	Turn the temperature dial to OFF, wait two minutes, then turn the unit back on to SMOKE or desired temperature. Safety feature prevents an inadvertent start.
	Power outage occurred while in operation.	
Flashing Dots on LCD Screen	The igniter is ON	This is not an error that effects the grill. Used to show that the unit is in Start-Up mode. The igniter will turn off after five minutes. Once the flashing dots turn off, the grill will begin to operate at the desired temperature selected.

Flashing Temperature on LCD Screen	Grill temperature is below 65°C /150°F	<p>This is not an error that effects the grill; however, it is used to show that there is some risk that the fire could go out.</p> <p>Check hopper for sufficient fuel or if there is an obstruction in the feed system. Remove pellets and follow Care and Maintenance instructions.</p> <p>Check grill temperature probe. Follow Care and Maintenance instructions if dirty.</p> <p>Check burn pot for ash build-up or obstructions. Follow Care and Maintenance instructions for ash build-up.</p> <p>Check fan. Ensure it is working properly and air intake is not blocked. Follow Care and Maintenance instructions if dirty.</p> <p>Check auger motor to confirm operation, and ensure there is no blockage in the auger tube.</p>
Grill Temperature on SMOKE is too high	"P" Setting is too LOW	<p>Turn the temperature dial to SMOKE, push the "P" SET button, and increase the "P" setting.</p> <p>When selecting a SMOKE setting after a temperature dial preset (such as preheating at high heat), the auger will continuously turn and feed pellets for four minutes. This will momentarily raise the temperature, but temperature will decrease and stabilize once the "P" setting cycle begins (approximately five to ten minutes).</p>
Grill displays unexpected temperature when OFF	Grill is exposed to high ambient temperature and direct sun	<p>This will not harm the grill. The internal temperature of the grill barrel has ambiently reached or exceeded 54°C / 130°F. Move the grill into a shaded area. Prop the lid open to reduce the internal temperature.</p>
Grill will not achieve or maintain stable temperature	Control settings	<p>The "P" setting is too high. Lowering the "P" setting will decrease large fluctuations in temperature. Push the "P" SET button, and decrease the "P" setting. Similar to a campfire, fueling the burn pot (fire) more frequently will result in less heat fluctuations. A lower "P" setting, such as P1, will provide the most stable temperature.</p>
	Insufficient air flow through burn pot	<p>Check burn pot for ash build-up or obstructions. Follow Care and Maintenance instructions for ash build-up.</p> <p>Check fan. Ensure it is working properly and air intake is not blocked. Follow Care and Maintenance instructions if dirty.</p> <p>Check auger motor to confirm operation, and ensure there is no blockage in the auger tube.</p> <p>Once all the above steps have been done, start the grill, set temperature to SMOKE and wait for 10 minutes. Check that the flame produced is bright and vibrant.</p>
	Insufficient or poor fuel	<p>Check hopper for sufficient fuel or if there is an obstruction in the feed system. Remove pellets and follow Care and Maintenance instructions.</p>
	Grill temperature probe	<p>Check grill probe. Follow Care and Maintenance instructions if dirty.</p>
Grill produces excess or discolored smoke	Grease build-up	<p>Follow Care and Maintenance instructions.</p>
	Wood pellet quality	<p>Remove moist wood pellets from hopper. Follow Care and Maintenance instructions to clean out. Replace with dry wood pellets.</p>
	Burn pot is blocked	<p>Clear burn pot of moist wood pellets. Follow Hopper Priming Procedure.</p>
Frequent Flare-Ups	Cooking Temperature	<p>Attempt cooking at a lower temperature. Grease does have a flash point. Keep the temperature under 176°C / 350°F when cooking highly greasy food.</p>

ELECTRICAL WIRE DIAGRAM

The Digital Control Board system is an intricate and valuable piece of technology. For protection from power surges and electrical shorts, consult the wire diagram below to ensure your power source is sufficient for the operation of the unit.

PB – ELECTRIC REQUIREMENTS

110-120V, 3.3AMP, 60HZ, 275W, 3-PRONG GROUNDED PLUG

NOTE: Electrical components, passed by product safety testing and certification services, comply with a testing tolerance of ± 5-10 percent.

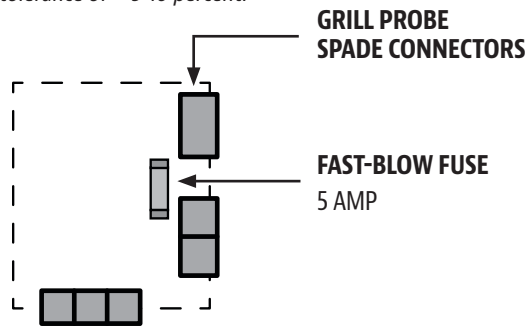
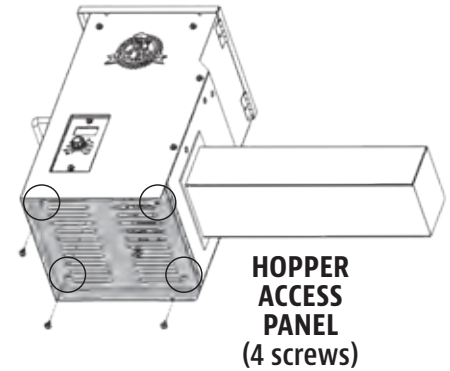

DIGITAL CONTROL BOARD

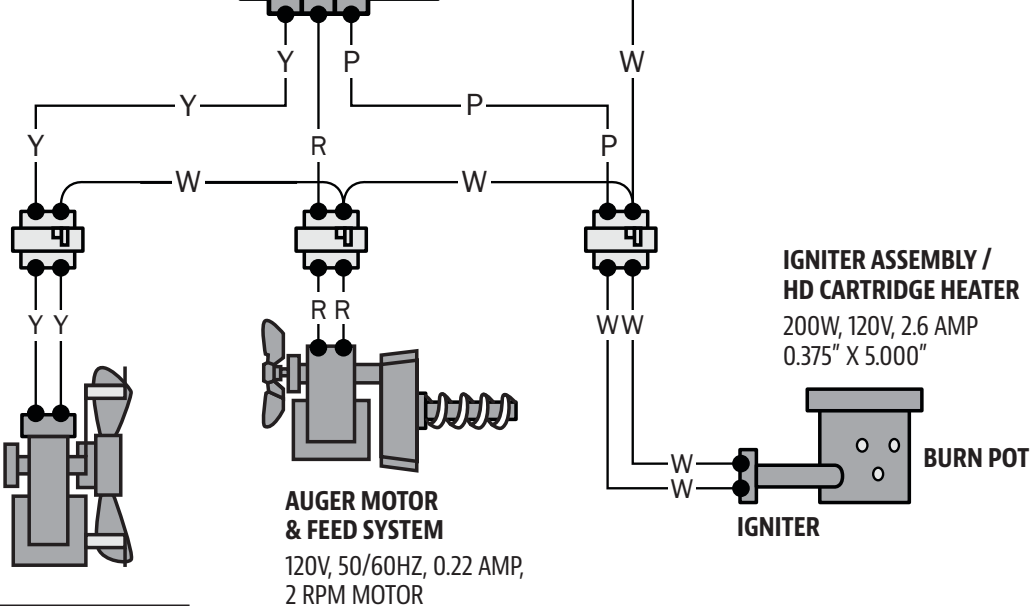
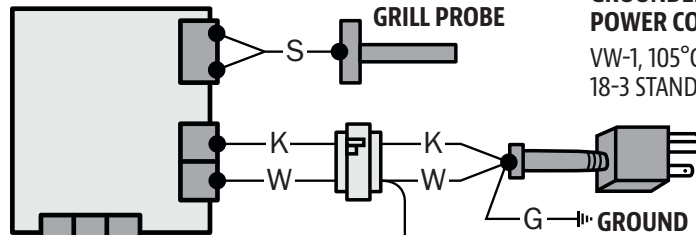

INDEX

W : WHITE	K : BLACK
Y : YELLOW	S : SILVER
P : PURPLE	G : GREEN
R : RED	

FUEL INPUT RATING: 1.12 KG/H (2.48 LB/H)
ELECTRICAL RATING: 265W, 2.5A, 120V

REPLACEMENT PARTS

Part#	Description
1-A	Porcelain-Coated Cast-Iron Cooking Grids (x2)
2-A	Lid Stopper
3-A	Flame Diffuser
4-A	Hopper Assembly
5-A	Main Barrel
6-A	Bezel (x2)
7-A	Lid Handle
8-A	Metal Wheels (x2)
9-A	Stationary Leg (x2)
10-A	Leg with Wheel Axle (x2)
11-A	Grease Bucket
12-A	Bottom Shelf
13-A	Screw (x27)
14-A	Washer (x2)
15-A	Lock Nut (x2)
16-A	Washer (x27)
17-A	Locking Washer (x27)

NOTE: Due to ongoing product development, parts are subject to change without notice.

PB – ELECTRIC REQUIREMENTS

110-120V, 3.3AMP, 60HZ, 275W, 3-PRONG GROUNDED PLUG

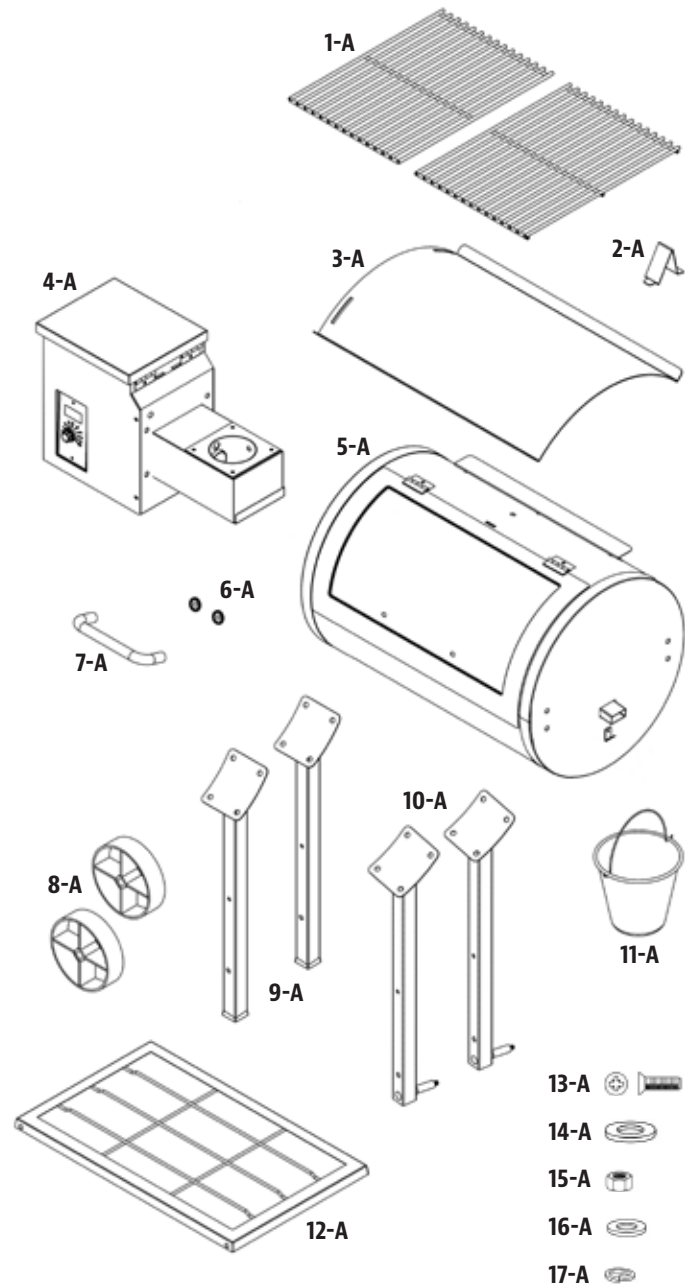

REPLACEMENT PARTS

Part#	Description
1-PH	Fire Pot
2-PH	Auger Box Gasket
3-PH	Igniter (Hot Rod)
4-PH	Auger Flighting
	Auger Shaft Bolt
	Auger Motor Shaft Lock Nut
5-PH	Hopper Box Housing
6-PH	Pit Boss Control Board
7-PH	Auger Motor
8-PH	Nylon Bushing
9-PH	Combustion Fan
10-PH	Auger Box Housing
11-PH	Hopper Assembly / Grill Body Gasket
12-PH	Grill Probe

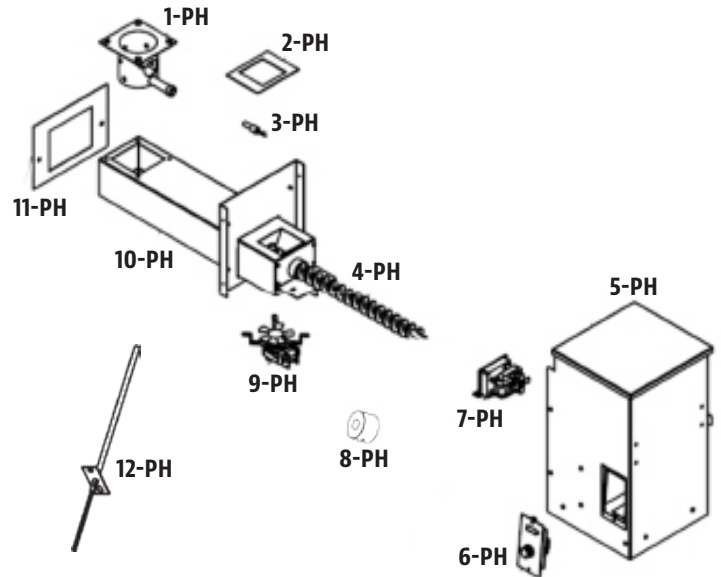

WARRANTY

CONDITIONS

All wood pellet grills by Pit Boss, manufactured by Dansons Inc., carry a limited warranty from the date of sale by the original owner. The warranty coverage begins on the original date of purchase and proof of date of purchase, or copy of original bill of sale, is required to validate the warranty. Customers will be subject to parts, shipping, and handling fees if unable to provide proof of the purchase or after the warranty has expired.

Dansons carries a one (1) year warranty against defects and workmanship on all parts, and one (1) year on electrical components. Dansons warrants that all part(s) are free of defects in material and workmanship, for the length of use and ownership of the original purchaser. Warranty does not cover damage from wear and tear, such as scratches, dents, dings, chips or minor cosmetic cracks. These aesthetic changes of the grill do not affect its performance. Repair or replacement of any part does not extend past the limited warranty beyond the one (1) year from date of purchase.

During the term of the warranty, Dansons' obligation shall be limited to furnishing a replacement for defective and/or failed components. As long as it is within the warranty period, Dansons' will not charge for repair or replacement for parts returned, freight prepaid, if the part(s) are found by Dansons' to be defective upon examination. Dansons' shall not be liable for transportation charges, labor costs, or export duties. Except as provided in these conditions of warranty, repair or replacement of parts in the manner and for the period of time mentioned heretofore shall constitute the fulfillment of all direct and derivate liabilities and obligations from Dansons to you.

Dansons takes every precaution to utilize materials that retard rust. Even with these safeguards, the protective coatings can be compromised by various substances and conditions beyond Dansons' control. High temperatures, excessive humidity, chlorine, industrial fumes, fertilizers, lawn pesticides and salt are some of the substances that can affect metal coatings. For these reasons, the warranty does not cover rust or oxidization, unless there is loss of structural integrity on the grill component. Should any of the above occur, kindly refer to the care and maintenance section to prolong the lifespan of your unit. Dansons recommends the use of a grill cover when the grill is not in use.

This warranty is based on normal domestic use and service of the grill and neither limited warranty coverage's apply for a grill which is used in commercial applications.

EXCEPTIONS

There is no written or implied performance warranty on Pit Boss grills, as the manufacturer has no control over the installation, operation, cleaning, maintenance or the type of fuel burned. This warranty will not apply nor will Danson's assume responsibility if your appliance has not been installed, operated, cleaned and maintained in strict accordance with this owner's manual. Any use of gas not outlined in this manual may void the warranty. The warranty does not cover damage or breakage due to misuse, improper handling or modifications.

Neither Danson's, or authorized Pit Boss dealer, accepts responsibility, legal or otherwise, for the incidental or consequential damage to the property or persons resulting from the use of this product. Whether a claim is made against Danson's based on the breach of this warranty or any other type of warranty expressed or implied by law, the manufacturer shall in no event be liable for any special, indirect, consequential or other damages of any nature whatsoever in excess of the original purchase of this product. All warranties by manufacturer are set forth herein and no claim shall be made against manufacturer on any warranty or representation.

Some states do not allow the exclusion or limitation of incidental or consequential damages, or limitations of implied warranties, so the limitations or exclusions set forth in this limited warranty may not apply to you. This limited warranty gives you specific legal rights and you may have other rights, which vary from state to state.

ORDERING REPLACEMENT PARTS

To order replacement parts, please contact your local Pit Boss dealer or visit our online store at: www.pitboss-grills.com

CONTACT CUSTOMER SERVICE

If you have any questions or problems, contact Customer Service, Monday through Friday, 8am to 5pm MST (English /French).

service@pitboss-grills.com | Toll-Free: 1-877-303-3134 | Toll-Free Fax: 1-877-303-3135

WARRANTY SERVICE

Contact your nearest Pit Boss dealer for repair or replacement parts. Danson's Inc. requires proof of purchase to establish a warranty claim; therefore, retain your original sales receipt or invoice for future reference. The serial and model number of your Pit Boss can be found inside the lid of the hopper. Record numbers below as the label may become worn or illegible.

MODEL

SERIAL NUMBER

DATE OF PURCHASE

AUTHORIZED DEALER

ACCESSORIES SOLD SEPARATELY

Available for purchase separately. Accessories not available and supplied by all authorized Pit Boss dealers.

ITEM	DESCRIPTION	ITEM	DESCRIPTION
	GRILL COVER Form-fitting, full length cover. Heavy-duty polyester with PVC backing for long-term use. Weatherproof. Includes draw-string lock for easy tightening.		GRILLING APRON Adjustable apron with double front pockets for grilling tools. One size. Machine washable.
	BBQ FLOOR MAT Easy clean, UV protected. Protection for your deck. 132cm x 86cm / 52" x 34"		
	SIDE SHELF - BLACK Black, solid shelf. Complete with tool hooks and towel bar. Mounts to side of main barrel.		SIGNATURE SAUCES A collection of gourmet sauces to prepare and enhance the natural flavors of your food.
	SIDE SHELF - STAINLESS Stainless steel shelf. Removable tray doubles as a grilling and serving tray. Complete with tool hooks. Mounts to side of main barrel.		SIGNATURE SPICES A collection of gourmet seasonings to prepare and enhance the natural flavors of your food.

RECIPES

CLASSIC BRISKET

Makes 4 - 6 Servings

A whole beef brisket weighs 7.25-3.62 kg / 16-18 pounds and has three separate parts: the cap, the point, and the flat. Use the flat section, as it is lean, compact, and creates nice slices when carved.

Ingredients:

1	Beef Brisket <small>2.2-3.6 kg / 5-8 lbs, Layer of fat is at least 0.6 cm / ¼" thick</small>
1 bottle	Prepared Yellow Mustard
75 ml / 5 tbsp	Seasoning
1 bottle	Chili Sauce
1 pack	Dry Onion Soup Mix
375 ml / 1½ c.	Beef Broth
40 ml / 8 tsp	Black Pepper

Suggested Wood Pellet Flavor: Hickory / Competition

Instructions:

1. Lay out a large piece of plastic wrap on your working station. Large enough to encase the brisket. Using a sharp knife, cut a single cut on the underside of the brisket against the grain. This will aid in slicing the finished brisket, against the grain which results in a tender, melt-in-your-mouth cut. The underside is the non-fat cap side. Slather on a generous amount of prepared mustard. Rub lightly onto the entire area. Sprinkle a generous amount of seasoning onto the mustard, then again light rub into the meat. Flip the brisket over and repeat the process. Wrap the prepared brisket in the plastic wrap and refrigerate 2 to 4 hours, or overnight.
2. Prepare the basting mixture. Mix the chili sauce, dry onion soup mix, beef broth, and black pepper. Set aside.
3. **Preheat grill, then reduce to SMOKE or low temperature.**
4. Place the brisket, fat side up, in the center of the grill. Close the grill lid. Slow cook until tender, about 10 to 12 hours.
5. Baste the brisket with the basting mixture every half hour for the first 3 hours.
6. Continue the slow cooking process until the internal temperature reaches 60-66°C / 140-150°F. Remove from grill. **Turn grill up to 176°C / 350°F.**
7. Place the brisket into a pouch of double-layered aluminum foil. Pour 50 ml / ¼ cup of basting mixture over the brisket in the pouch. Close the pouch shut.
8. Lay foil pouch carefully on the grill. Steam for 1 to 1½ hours.
9. Open the pouch, and use a meat thermometer; internal temperature should reach 77°C / 170°F. The brisket should be firm but be able to pull the meat apart with your fingers.
10. Transfer the meat to a cutting board, and let it rest for 10 minutes. Thinly slice across the grain to serve.

SAUSAGE WITH MANGO CHUTNEY

Makes 4 - 6 Servings

Ingredients:

2	Mangoes (finely chopped)
0.9 kg / 2 lbs	Italian Sausage (hot or mild)
10 ml / 2 tsp	Fresh Parsley (minced)
15 ml / 1 tbsp	Red Pepper (diced)
10 ml / 2 tsp	Honey
½	Red Onion (diced)
½ bulb	Fennel (diced)
5 ml / 1 tsp	Lime Juice
Pinch	Salt

Suggested Wood Pellet Flavor: Hickory / Competition

Instructions:

1. **Preheat grill, then reduce to LOW-MEDIUM (27-107°C / 180-225°F)**
2. Place sausages on grill, spaced evenly apart. Rotate every ten minutes so all sides are grilled.
3. Combine all remaining ingredients to make the chutney. Chill until ready to serve.
4. Slice grilled sausage diagonally, then serve with side of chutney.

BLUE CHEESE STEAK

Makes 4 Servings

Ingredients:

4	Steak, T-bone or Rib-Eye <small>2.54cm / 1" thick 0.28-0.62 kg / 10-12 ounces each</small>
113 g / 4 oz.	Blue Cheese (crumbled)
50 ml / ¼ c.	Green Onion (thinly sliced)

Suggested Wood Pellet Flavor: Hickory / Competition / Whiskey

Instructions:

5. **Preheat grill, then leave or reduce slightly (204-260°C / 400-500°F)**
6. Trim excess fat from meat and discard.
7. Place steaks on grill. Sear each side, flipping every few minutes.
8. **Reduce heat to 135°C/275°F or 163°C/ 325°F.** Flip the steaks a final time. Combine blue cheese and onions. Sprinkle over steaks, close grill lid, and grill until desired doneness. Check doneness by cutting a slit in meat near the bone.

Variation: REVERSE-SEAR METHOD

Turn grill to SMOKE, then place steaks on grill. Smoke at 82°C / 180°F for 5 to 15 minutes. Once smoked to desired doneness, turn grill up to HIGH and sear to your liking.

BBQ RIBS

Makes 4 - 6 Servings

Ingredients:

1.3-1.8 kg / 3-4 lbs	Ribs
	<small>Meaty pork spareribs / loin back ribs</small>
45 ml / 3 tbsp	Oil
5 ml / 1 tsp	Salt
5 ml / 1 tsp	Pepper
2 whole	Onions (chopped)
30 ml / 2 tbsp	Vinegar
30 ml / 2 tbsp	Worcestershire sauce
125 ml / ½ c.	Apple Juice or Soda
5 ml / 1 tsp	Paprika
5 ml / 1 tsp	Chili Powder

Suggested Wood Pellet Flavor: Hickory / Competition / Apple

Instructions:

1. **Preheat grill, then reduce to SMOKE or low (82-107°C / 180-225°F).**
2. Prepare ribs by peeling off the tough layer of skin on the back side. Season the ribs with salt and pepper, to taste.
3. Place ribs on grill, spaced evenly apart. Smoke for 3 to 4 hours.
4. Mix remaining ingredients in a saucepan and bring to a boil. Let sauce boil for five minutes to thicken.
5. Remove from grill. **Turn grill up to 176°C / 350°F.**
6. Place each rack into a pouch of double-layered aluminum foil. Pour 50 ml / ¼ cup of sauce over the ribs in the pouch. Close the pouch shut.
7. Lay foil pouch carefully on the grill. Steam for 1 to 1½ hours.
8. Open the pouch. The meat will have exposed the rib ends and be very tender. **Turn grill up to HIGH (260°C / 500°F).** Place ribs back on the grill and baste with sauce on both sides of ribs.
9. Once the sauce is caramelized and the ribs are sticky, remove from grill and serve.

Variation: MEMPHIS-DRY METHOD

Turn grill up to HIGH (260°C / 500°F). Place ribs back on the grill and season with a dry seasoning or rub. Sear the ribs, remove from grill and serve.

MOM'S JUICY HAMBURGERS

Makes 4 - 6 Servings

Ingredients:

900 g / 2 lbs	Ground Beef or Buffalo
15 ml / 3 tsp	Seasoning
2 whole	Eggs, room temperature
500 ml / 2 c.	Bread Crumbs (Dried, Fine)
6 - 8	Hamburger / Kaiser Buns
6 - 8 slices	Cheese (slices, thin)
30 ml / 2 tbsp	Butter

Suggested Wood Pellet Flavor: Hickory / Competition

Instructions:

1. **Preheat grill, then leave or reduce slightly (204-260°C / 400-500°F)**
2. Combine meat, seasoning, eggs and bread crumbs in a mixing bowl and blend together. Divide the meat into portions, and gently shape into patties to fit the buns. Make patties about 1.9 cm / ¾ inches thick.
3. Place patties on grill. Grill six minutes per side, taking care not to press down on the meat. Test for doneness, using a meat thermometer; internal temperature should reach 71°C / 160°F. Meat may turn pink on the outside due to smoking.
4. In the last few minutes of grilling, brush buns with butter and lightly toast on the grill.
5. Remove buns, burgers when done. Top the burgers with cheese to melt, and serve.

TIP: A slightly fattier meat makes for a juicier burger. For a lean alternative, try ground buffalo.

SIRLOIN STEAK WITH SWEET ONION & PEPPERS

Makes 4 Servings

Ingredients:

2	Steak, Top Sirloin
	<small>1" thick, cut into 4 pieces. 0.45kg/1 lb</small>
10 ml / 2 tsp	Seasoning or rub
5 medium	Sweet Onions (coursed chopped)
2 whole	Bell Peppers (all kinds, chopped)
60 ml / 4 tbsp	Soy Sauce
60 ml / 4 tbsp	Olive Oil
Dash	Salt

Suggested Wood Pellet Flavor: Hickory / Mesquite / Whiskey

Instructions:

1. **Preheat grill, then reduce slightly to 218°C / 425°F.**
2. Season both sides of the steak with the seasoning or rub. Cover and refrigerate at least 1 hour.
3. Place onions and bell peppers into a covered tray of aluminum foil. Mix soy sauce and olive oil together, then drizzle over tray. Sprinkle with salt. Seal the foil packet completely.
4. Place the foil on the grill for 10 - 15 minutes or until vegetables are soft and tender. Remove from grill, and keep covered.
5. Place steaks on grill. Sear each side, flipping every few minutes.
6. Grill until desired doneness, then remove from grill. Place on serving plates and top with warm vegetables.

CORNISH HENS WITH MANDARIN RICE

Makes 4 Servings

Ingredients:

4 whole Cornish Game Hens
750 ml / 3 c. Mandarin Rice
15 ml / 1 tbsp Olive Oil
5 ml / 1 tsp Smoked Paprika
250 ml / 1 c. Orange Marmalade

Mandarin Rice

59 ml / ¼ c. Almonds (slivered)
30 ml / 2 tbsp Celery (chopped)
1 small Green Onion (sliced, thin)
30 ml / 2 tbsp Butter
1 can Mandarin Orange Segments (drained)
0.4 kg / 11oz.
30 ml / 2 tbsp Orange Juice (concentrate)
500 ml / 2 c. Cooked Rice

Suggested Wood Pellet Flavor: Hickory / Mesquite / Competition

Instructions:

1. Prepare mandarin rice by cooking almonds, celery, green onion, and butter in small skillet until almonds are lightly toasted. Combine mixture with orange segments, orange juice and cooked rice in a bowl, and set aside.
2. **Preheat grill, then reduce to MEDIUM (135-177°C / 275-350°F).**
3. Rinse Cornish hens and pat dry with paper towel. Stuff with rice mixture and tie legs with a string. Brush Cornish hens lightly with olive oil, and sprinkle with paprika.
4. Place Cornish hens on grill. Grill for 45 to 60 minutes, until the drumstick meat is tender when pressed.
5. Baste with orange marmalade during last 20 minutes of cooking time. Remove from grill and arrange on serving platter.

TIP: If you want to catch the drippings to make gravy, place the hens in a foil pan and add enough water or juice to cover the bottom about 0.6 cm / ¼ inch thick.

SHRIMP KABOBS WITH CURRY BUTTER

Makes 4 Servings

Ingredients:

900g / 2 lbs Shrimp (peeled, deveined)
125ml / ½ c. Curry Butter
15 ml / 1 tbsp Olive Oil
1 Lime
Fresh Dill

Curry Butter

125 ml / ½ c. Butter
30 ml / 2 tbsp Onion (chopped)
15 ml / 1 tbsp Fresh Dill
5 ml / 1 tsp Curry Powder
Dash Garlic Powder

Suggested Wood Pellet Flavor: Mesquite / Competition

Instructions:

1. Soak wooden skewers in water for 1 hour.
2. **Preheat grill, then reduce to 135-163°C / 275-325°F.**
3. Prepare curry butter by melting butter in small pan over medium-high heat. Stir in onion, dill, curry powder and garlic powder. Cook for five minutes, then remove from heat.
4. Thread shrimp on skewers, leaving space between pieces. Lightly brush with olive oil.
5. Place skewers on grill, and grill until shrimp are white and tender. Shrimp grill quickly; take care not to overcook. Turn skewers of shrimp once and brush with curry butter halfway through cooking time.
6. Arrange grilled shrimp on serving plate. Garnish with lime wedge and dill.

TIP: To skewer shrimp so that it is straight, hold it in a stretched-out position with one hand. Start at the tail end and insert a bamboo or wooden skewer into the shrimp so that it runs the full length. Keep unbending the shrimp with your fingers as you go.

BACON BASIL SHRIMP ON A STICK

Makes 4 - 6 Servings

Ingredients:

24 large Shrimp (peeled, deveined)
24 whole Fresh Basil Leaves
24 slices Bacon (sliced thin)

Suggested Wood Pellet Flavor: Cherry / Apple

Instructions:

1. Soak wooden skewers in water for 1 hour.
2. **Preheat grill, then reduce to 135-163°C / 275-325°F.**
3. Wrap a piece of shrimp and basil leaf in a thin slice of bacon, then thread onto skewer, leaving space between pieces.
4. Place skewers on grill, and cook until shrimp are white and tender, and the bacon is nicely browned. Shrimp grill quickly; take care not to overcook. Turn skewers often to avoid burning.
5. Remove from heat and serve.

WHOLE SMOKED TURKEY

Feeds a small army - leftovers are great!

Ingredients:

1 whole Turkey (thawed)
9-11.3 kg / 20-25 lbs
60 ml / 4 tbsp Seasoning
5 ml / 1 tsp Smoked Paprika
45 ml / 3 tbsp Butter

Suggested Wood Pellet Flavor: Hickory / Cherry / Competition

Instructions:

1. **Preheat grill, then reduce to 135-177°C / 275-350°F.**
2. Remove the turkey neck and giblets. Rinse turkey thoroughly and pat the exterior dry with paper towel.
3. In a small bowl, mix butter, ¼ of the seasoning and paprika together to form a paste. Gently insert your hand between the outer skin and the breast meat. Rub paste into the meat.
4. With the remaining seasoning, rub the outer surface of the turkey.
5. Place turkey, breast side up, in center of grill, and cook until turkey is tender and golden brown; internal temperature should reach 82°C / 180°F in the thickest part of the thigh and 77°C / 170°F in the breast.
6. Remove turkey, cover with foil and let rest for 10 minutes before carving.

TIP: If you want to catch the drippings to make gravy, place the turkey on a rack inside a large aluminum foil roast pan. Add 0.6 cm / ¼" of water or broth and some seasoning into the bottom of the pan. Monitor the juices, as you may need to add more during the roasting period.

BEER CAN CHICKEN

Makes 2 - 6 Servings

Ingredients:

1 whole Chicken
1.8-2.7 kg / 4-6 lbs
1 can Beer, any kind
45 ml / 3 tbsp Seasoning

Suggested Wood Pellet Flavor: Hickory / Apple / Competition

Instructions:

1. **Preheat grill, then reduce to 135-177°C / 275-350°F.**
1. Open can, and pour half of the beer into a glass to drink. Leave half in the can, and make a few more holes in the top of the can to increase ventilation. Add a ¼ of the seasoning to the can.
2. Rinse chicken thoroughly and pat the exterior dry with paper towel. Add a ¼ of the rub inside the cavity of the chicken. With the remaining seasoning, rub the outer surface of the chicken.
3. Insert the upright can into the cavity of the chicken, place on the grill, and close the grill lid. Cook until the chicken is golden

brown and crispy; internal temperature should reach 74°C/165°F.

4. Using tongs, carefully remove the upright chicken and can from the grill. Let rest for five minutes, then carefully remove the can from the cavity of the chicken. Be cautious not to spill, as the liquid will be hot.
5. Carve chicken and serve.

Variation: NON- ALCOHOLIC, BEER-CAN CHICKEN

Using the same instructions as above, but substitute the can of beer with a can of your favorite non-diet cola, fruit juice, or water with additional seasoning.

EASY RANCH CHICKEN SATAY

Makes 2 - 6 Servings

Ingredients:

450g / 1 lb Chicken Breasts or Thighs (boneless, skinless)
112 ml / ½ c. Prepared Ranch or Italian Salad Dressing
Dash Salt
Dash Pepper

Suggested Wood Pellet Flavor: Apple / Cherry

Instructions:

6. Cut chicken, lengthwise, into 0.63 cm / ¼" or slightly thicker pieces. Rinse chicken and pat dry with paper towel.
7. Place chicken pieces into a plastic lock-top bag. Add salad dressing, salt and pepper. Seal the bag closed, and carefully shake, coating chicken evenly. Place in refrigerator for 1 - 2 hours, or overnight. Shake the bag once or twice so the chicken marinades evenly.
1. Soak wooden skewers in water for 1 hour before use.
2. **Preheat grill, then reduce slightly to 218°C / 425°F.**
3. Remove chicken from plastic bag, and weave in-and-out onto the skewers, like a ribbon.
4. Place skewers on grill, and cook until chicken is white and firm. Turn skewers often to avoid burning.
5. Remove from heat and serve.



IMPORTANT

DO NOT RETURN PRODUCT TO STORE

Dansons Inc. stands behind our authorized dealers. Many dealers do stock replacement parts and accessories. We strongly suggest that if you need to order parts, options, or require service that you first consult your local dealer. Many dealers do stock current accessories, fuel and service parts.

For all other questions, comments, or inquiries, please contact Dansons Inc. directly. Our Pit Boss Grills Customer Service department is available Monday to Friday 8 am – 5pm MST.

**Contact Pit Boss Customer Service
(English/French)**

service@pitboss-grills.com

TOLL FREE: 1-877-303-3134

TOLL FREE FAX: 1-877-303-3135

VISIT US AT **WWW.PITBOSS-GRILLS.COM**
FOR ACCESSORIES, RECIPES & FAQs!

SHARE WITH US!



780170616UMV

